

1
2
3
4
5
6

2									
3									
4									
5									
6									

NO.		DESCRIPTION		MAT.(KS)		UNIT	TOTAL QUANTITY	PERCENT	TOTAL WORKING	REMARK'S
woorim MAKING MACHINERY										
TITLE: LIFTING STATION PLANETARY GEAR										
SCALE: 1/14 PROJECTION: 4E										
SHEET NO. 1 OF 1										
DRAWING NO. WRPR-1565										
NO.	DATE	REVISIONS & DESCRIPTION	DRAWN	CHECKED	REVIEWED	APPROVED	CUSTOMER		REV.	

Torsion Shaft Support

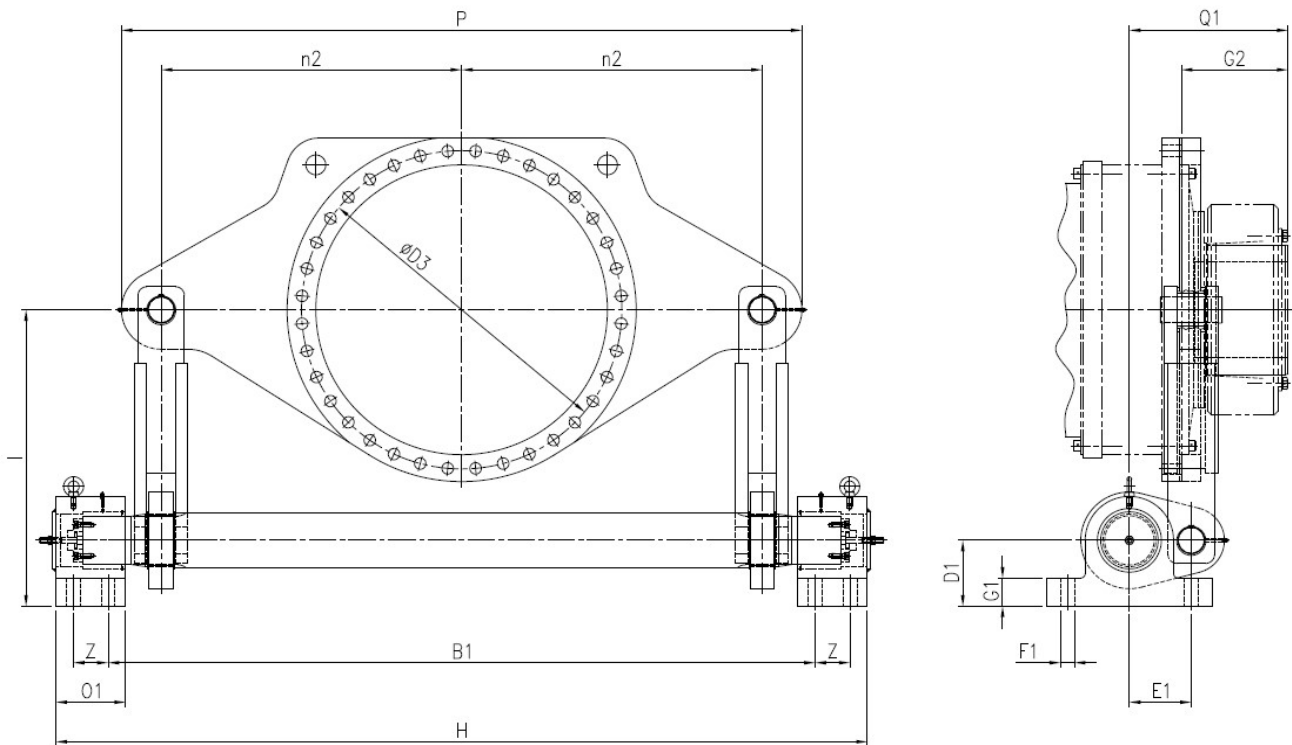

(UNIT : mm)

Size	torque (Nm)	A ₁	B ₁	D ₃	D ₁	E ₁	F ₁	No.	G ₁	G ₂	H	I	I ₁	n ₂	O ₁	P	Q ₁	Z	Weight (kg)
9	22 000	250	1320	610	120	105	33	8	48.5	165	1525	560	330	550	140	1230	247.5	65	325
10	31 000	250	1320	610	120	105	33	8	48.5	174	1525	560	330	550	140	1230	256.5	65	325
11	42 000	250	1320	610	120	105	33	8	48.5	204	1525	560	330	550	140	1230	286.5	65	325
12	60 000	250	1320	610	120	105	33	8	48.5	224	1525	560	330	550	140	1230	306.5	65	325
13	83 000	280	1547	775	155	145	39	8	68.5	241	1780	620	380	65	158	1450	358.5	75	620
14	117 000	280	1547	775	155	145	39	8	68.5	278	1780	620	380	650	158	1450	395.5	75	620
16	160 000	280	1547	775	155	145	39	8	68.5	285	1780	620	380	650	158	1450	402.5	75	620
17	202 000	35	1777	775	170	165	39	8	73.5	294	2041	700	400	750	180	1680	431.5	84	900
18	244 000	315	1777	955	170	165	39	8	73.5	303	2041	700	400	750	180	1680	440.5	84	900
19	295 000	350	2000	955	195	175	45	8	83.5	328	2300	860	450	850	200	1900	470.5	100	1200
20	354 000	350	2000	985	195	175	45	8	83.5	328	2300	860	450	850	200	1900	470.5	100	1200
21	392 000	400	2254	985	210	190	5	8	88.5	354	2591	900	530	950	225	2110	506.5	113	1500
22	450 000	400	2254	1120	210	190	45	8	88.5	354	2591	900	530	950	225	2110	506.5	113	1500
23	513 000	450	2496	1120	235	220	45	8	98.5	380	2871	1060	590	1063	250	2385	562.5	125	2150
24	592 000	450	2496	1215	235	220	45	8	98.5	380	2871	1060	590	1063	250	2385	562.5	125	2150
25	684 000	500	2816	1215	275	245	52	8	118.5	407	3236	1200	650	1150	280	2600	614.5	140	2650
26	763 000	500	2816	1350	275	245	52	8	118.5	407	3236	1200	650	1150	280	2600	614.5	140	2650
27	852 000	530	2887	1350	300	255	52	8	128.5	453	3327	1250	700	1250	290	2820	670.5	150	3250
28	950 000	530	2887	4190	300	255	52	8	128.5	453	3327	1250	700	1250	290	2820	670.5	150	3250
29	1 060 000	560	3200	1490	300	280	62	8	128.5	483	3673	1350	750	1360	315	3080	718	158	3900
30	1 200 000	560	3200	1565	300	280	62	8	128.5	483	3673	1350	750	1360	315	3080	718	158	3900
31	1 330 000	90	3408	1695	340	300	70	8	148.5	538	3906	1400	790	1450	330	3260	788	168	5050
32	1 500 000	590	3408	1695	340	300	70	8	148.5	538	3906	1400	790	1450	330	3260	788	168	5050
33	1 680 000	620	3588	1785	375	320	70	8	158.5	573	4116	1500	840	1550	350	3520	840.5	178	6800
34	1 920 000	620	3588	1785	375	320	70	8	158.5	573	4116	1500	840	1550	350	3520	840.5	178	6800
35+36	On request																		